

NN6-1130



- MPEG2 interface (DVB, ATSC)
- Serial to Parallel interface
- Outputs SPI (LVDS or TTL)
- Conversion from ASI or M2S
- TS packet size changing
- PCR Restamping
- Power redundancy
- Fault relay alarm
- ASI/M2S input + loopthrough
- DVB SPI outputs (LVDS or TTL)

Product highlights

- Cost effective converter
- Compact : 103mm width
- Robust
- 19" 1RU rack mountable
- Professional quality



DVB ASI to SPI (LVDS/TTL) Interface Converter

Facing an interworking issue ?

Looking for Interface Conversion solutions in:

- Broadcasting chain migration
- Interoperability issue in R&D
- Systems integration
 - Connection of test & monitoring equipments... ?

ENENSYS™ Technologies can help you solve your problem!

With its Baseband Converters and Network Adapters product lines for DVB and ATSC, ENENSYS Technologies masters B2B interoperability solutions for broadcasting professionals.

NN6-1130 interface converts any MPEG2 Transport Stream carried over DVB ASI to the SPI parallel format (either LVDS or TTL electrical signaled).

Delivered as stand alone interface, NN6-1130 **DVB-ASI to SPI (LVDS/TTL) converter** is fed by a high MTBF external power supply. It can be used on a lab working desk, or for demonstration purpose. It can also be rack-mounted for easy integration in a Digital Broadcast chain.

▶▶ **Interface converter comes standard with fault relay, packet size changing and power redundancy capabilities.**

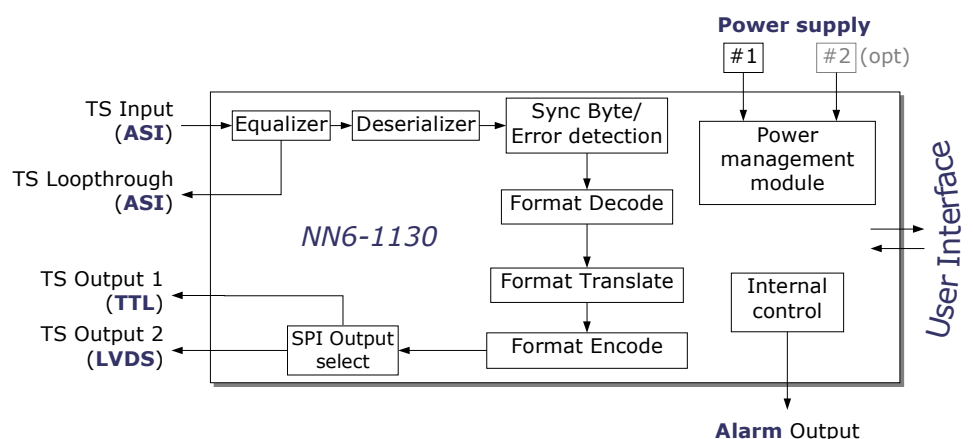

▶▶ Designed to meet your professional requirements !

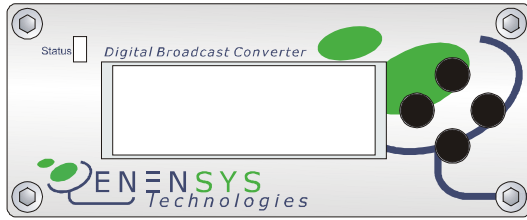

103 mm

ORDERING CODE	
NN6-1130EU	EU plug
NN6-1130UK	UK plug
NN6-1130US	US plug

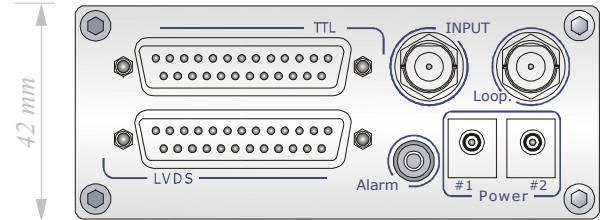

42 mm

ASI to SPI (LVDS/TTL) conversion

ASI (byte or continuous mode) input supported, converted signal is driven to two separate outputs (LVDS or TTL).

Packet size changing

MPEG2 Transport Stream packet size of **188 or 204 bytes per packet** is automatically detected at input, and output framing can be set to 188, 188+16 or 204 bytes per packet where bandwidth allows it.

Alarm generation

alarm activation can be set on power, framing errors, signal quality. Compatible with major alarm & redundancy management systems.

Power redundancy

by addition of a second external power supply.

Rack-mount kit

easily fits into crowded 19" equipment racks. Up to 4 converting units can be hosted by a 1U sub-rack.

Professional quality

NO COMPROMISE DESIGN using the best parts available wherever possible, including gold plated connectors, lead-free board plates, robust aluminium chassis, high MTBF power supply.

Safety and EMC figures

converter + its PSU fully meet requirements emitted by CE and FCC certification bodies.

INPUT	
Serial data input	MPEG2 Transport Stream (ISO-IEC 61883)
Data format	ASI (Asynchronous Serial Interface) As per DVB A010 ASI-C, EN50083-9
Connector	1x BNC 75 ohms
ASI Equalization	Short or long cable length optimization
Max bit rate	216 Mbps
ASI mode	Burst or Continuous - autodetection
Packet framing	188/204 bytes per packet - autodetection

OUTPUTS	
Parallel outputs	MPEG2 Transport Stream (ISO-IEC 61883)
Data format #1	DVB-SPI (LVDS): Low Voltage Differential Signal As per EN50083-9, DVB A010
Or	DVB-SPI (TTL): Transistor-Transistor Logic As per EN50083-9, DVB A010
Connectors	1x D-Sub 25 (LVDS) 1xD-Sub 25 (TTL)
Max bit rate	108 Mbps (operation up to 216 Mbps possible)
Packet format	188, 188+16 or 204 bytes per packet - user defined

Loopthrough	
Connector	1x BNC 75 ohms
ASI mode	Same as input (burst or continuous)
Packet framing	Same as input

ALARM / STATUS	
ALARM	1x alarm output (Jack 3.5mm: dry relay) Can be connected to Dry relay / SNMP module Compatible with alarm manager systems
Status led	3 levels state indicator

MECHANICAL	
Dimensions (whd)	103x42x165 (in millimeters) 4.13x1.65x6.30 (in inches)
Weight	0.5 kg (1.1 lb)

GENERAL	
Power supply	External supply unit (<i>included: specify plug type</i>)
Connectors	1+1 DC inputs (load balancing ready)
Power redundancy	Achieved by the use of a second adapter (<i>optional</i>)
User Interface	LCD and buttons on front panel
Rack mount option	19" mounting kit hosting 4 converters (1RU height)

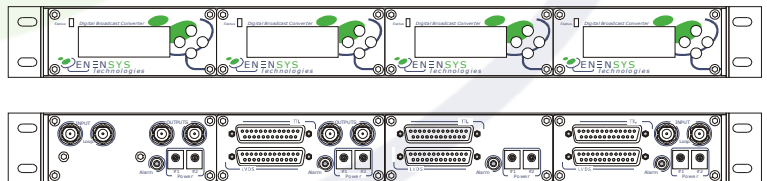

About ENENSYS Technologies:

ENENSYS Technologies proposes a large range of Digital TV interfaces surely meet your interoperability needs in the field of MPEG2 signals. With its Baseband Converters line, ENENSYS Technologies provides solutions to interface MPEG2 DVB or ATSC baseband signals over DVB-ASI, M2S, M2P, DVB-SPI (LVDS, TTL), RS-422, SSI, SMPTE-310, DHEI...

ENENSYS Technologies

Le Germanium
80 avenue des Buttes de Coesmes
35700 Rennes
FRANCE

Office (+33) 1 70 72 5170
Fax (+33) 2 99 36 03 84
contact@enensys.com

ACCESSORIES	ORDERING CODE
External Power Supply Unit (EU plug)	NN6-PSEU
External Power Supply Unit (UK plug)	NN6-PSUK
External Power Supply Unit (US plug)	NN6-PSUS
19" Rack mount kit	NN6-RCKM
Coax cable 75 ohms (5 meters)	NN6-CX75
Parallel 25 pins cable (1.5 meters)	NN6-PC25
SMB to BNC adapter	NN6-BBAD

www.enensys.com